

## Product datasheet

Curtain-type dock shelter with parallel guide system

Type: PMV

**Contact:**



Ronnenberger Straße 20  
D-30989 Gehrden

phone +49 (0) 5108 879 270  
fax +49 (0) 5108 879 2710

info@promstahl.de  
www.promstahl.de

# Mechanical dock shelter (PMV)

The mechanical dock shelter PMV is a new product of PROMStahl's wide product range. Various dimensions of warehouse openings and of the docked vehicles result in gaps which have to be sealed in the best possible way.

The front and the rear frame of the PROMStahl dock shelter consist of high-stability extruded aluminum sections connected to each other by bracing arms. The curtain is 3 mm thick, made of highly wear and tear resistant double-layer PVC-coated cloth and mounted on the flexible frame. Thanks to the adaptable roof and the parallel guide systems the front structure moves backward in the case of inaccurate docking, hence preventing damage to the dock shelter. The front part of the dock shelter is provided with warning stripes to facilitate the docking process. An integrated rain channel allows lateral drainage of rainwater (optional). The standard version of the dock shelter is provided with a slit in the left and right-hand corner. Partially or completely slit top curtains are available at little surcharge.

The PMV dock shelter is pre-mounted and consists of just three parts; therefore, it can be mounted to the façade very fast and easily. Considerable savings regarding time and money are the decisive advantages of this design.

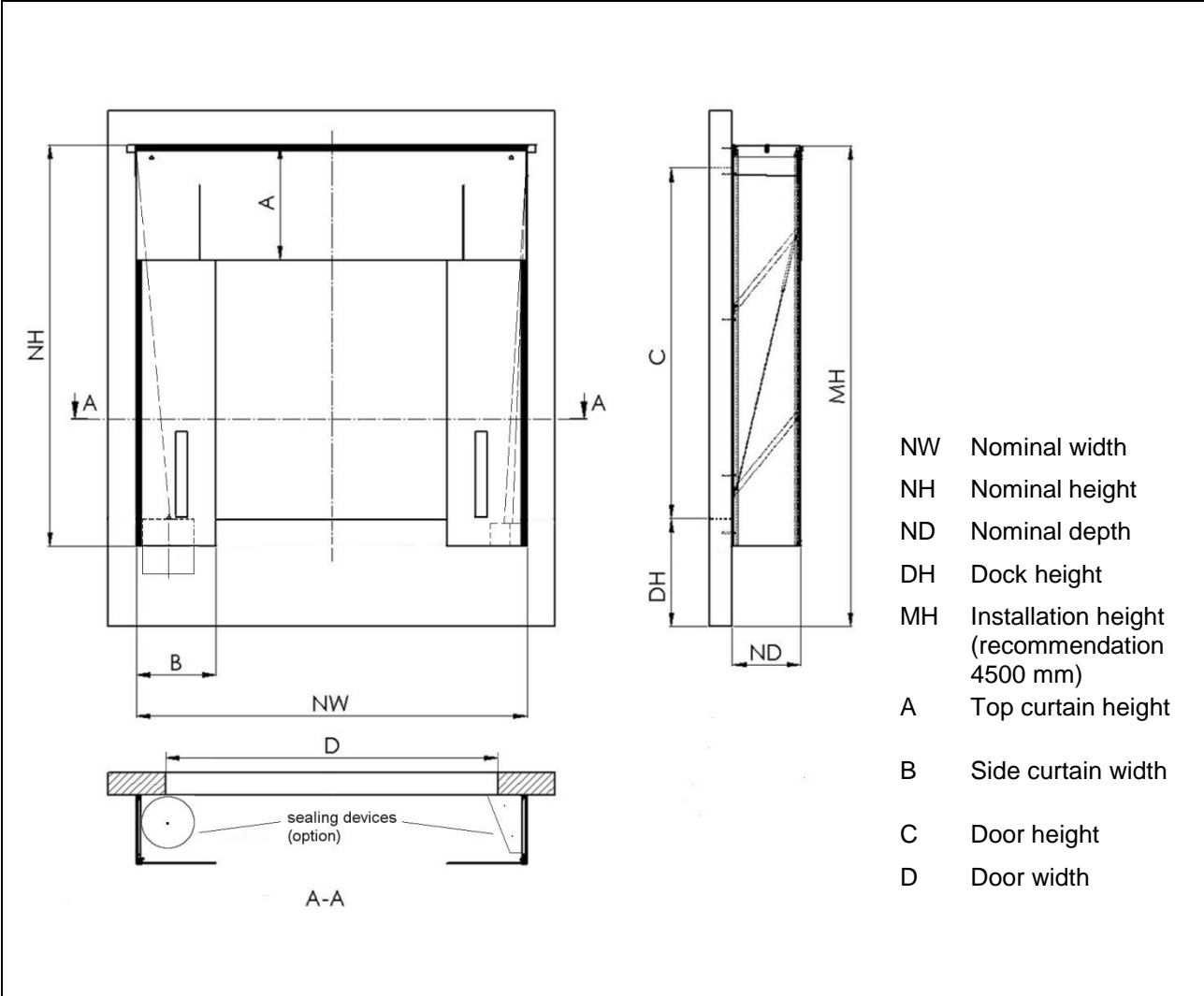

## Standard parameters

Nominal width of the dock shelter (NW):	3250 mm, 3300 mm, 3400 mm, 3450 mm
Nominal height of the dock shelter (NH):	3200 mm, 3400 mm, 3500 mm, 3600 mm
Nominal depth of the dock shelter (ND):	600 mm
Height of the top curtain (A):	1000 mm
Width of the side curtain (B):	600 mm (up to NW 3400 mm) 700 mm (from NW 3450 mm)

## Options

Nominal depth of the dock shelter (ND):	900 mm
Height of the top curtain (A):	1200 mm, 1500 mm
Others	Top curtain with corner slits Slit top curtain Sealing devices Number on the top curtain Yellow warning stripes Reinforcement of the side curtains by rubber flaps (1x per side)

## Curtain specification

Top curtain and side curtain characteristics:

- double-layer PVC-coated polyester cloth
- total weight: about 3800 g/m<sup>2</sup> in accordance with the EN ISO 2286-2 standard
- material thickness: 3 mm
- temperature stability: -25° C/ +70° C
- low flammability in accordance with the DIN 75200 standard
- tensile strength / maximum tensile force in accordance with DIN EN ISO 1421/V1
  - longitudinal tensile strength: about 7000 N/ 50 mm
  - transverse tensile strength: about 4300 N/ 50 mm
- tear propagation strength in accordance with DIN 53363
  - longitudinal tear propagation strength: about 1000 N
  - transverse tear propagation strength: about 900 N

Continuous curtain characteristics:

- single-layer PVC-coated polyester cloth
- total weight: about 600 g/m<sup>2</sup> in accordance with EN ISO 2286-2
- material thickness: 0,5 mm
- temperature stability: -40° C/ +70° C
- low flammability in accordance with DIN 75200
- tensile strength / maximum tensile force in accordance with DIN EN ISO 1421/V1
  - longitudinal tensile strength: about 2000 N/ 50 mm
  - transverse tensile strength: about 2000 N/ 50 mm
- tear propagation strength in accordance with DIN 53363
  - longitudinal tear propagation strength: about 200 N
  - transverse tear propagation strength: about 150 N

## Options

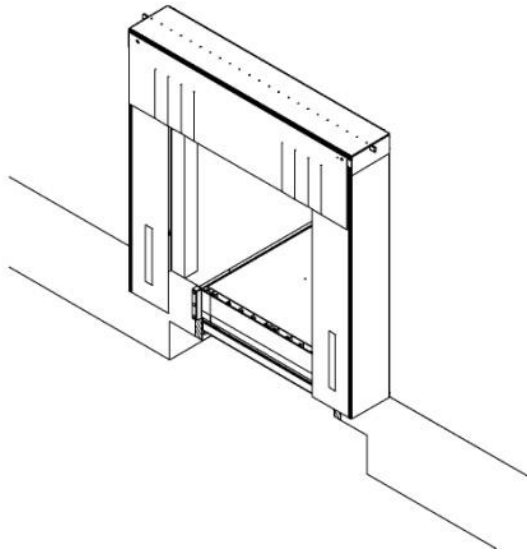

### Top curtain with corner slits

Each of the two edges of the top curtain is cut twice and completely covered by four 20 cm flaps resulting in optimum sealing of the vehicle corners.

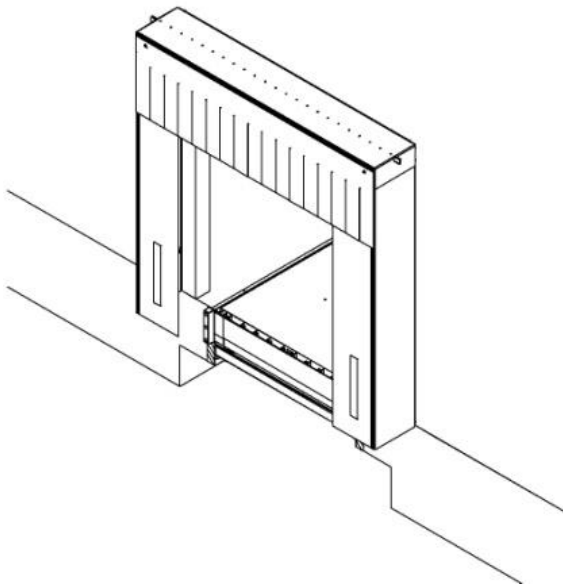

### Slit top curtain

The top curtain is reinforced by means of cloth inlays. The sealing effect is optimized thanks to the completely overlapping laterally staggered flaps.

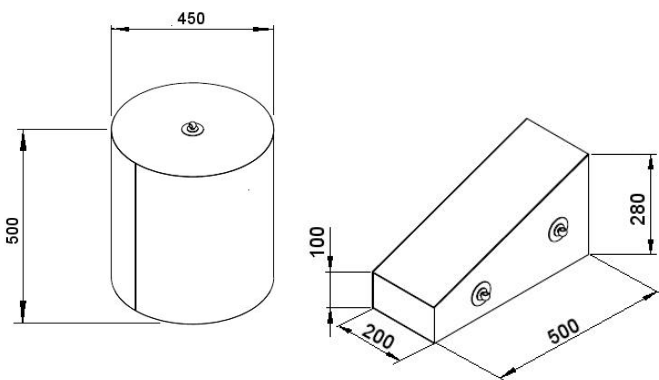

### Sealing devices

The corner seals and bumpers are coated with high-resistant PVC material and guarantee perfect protection against draught during loading and unloading.

# PMV fixing

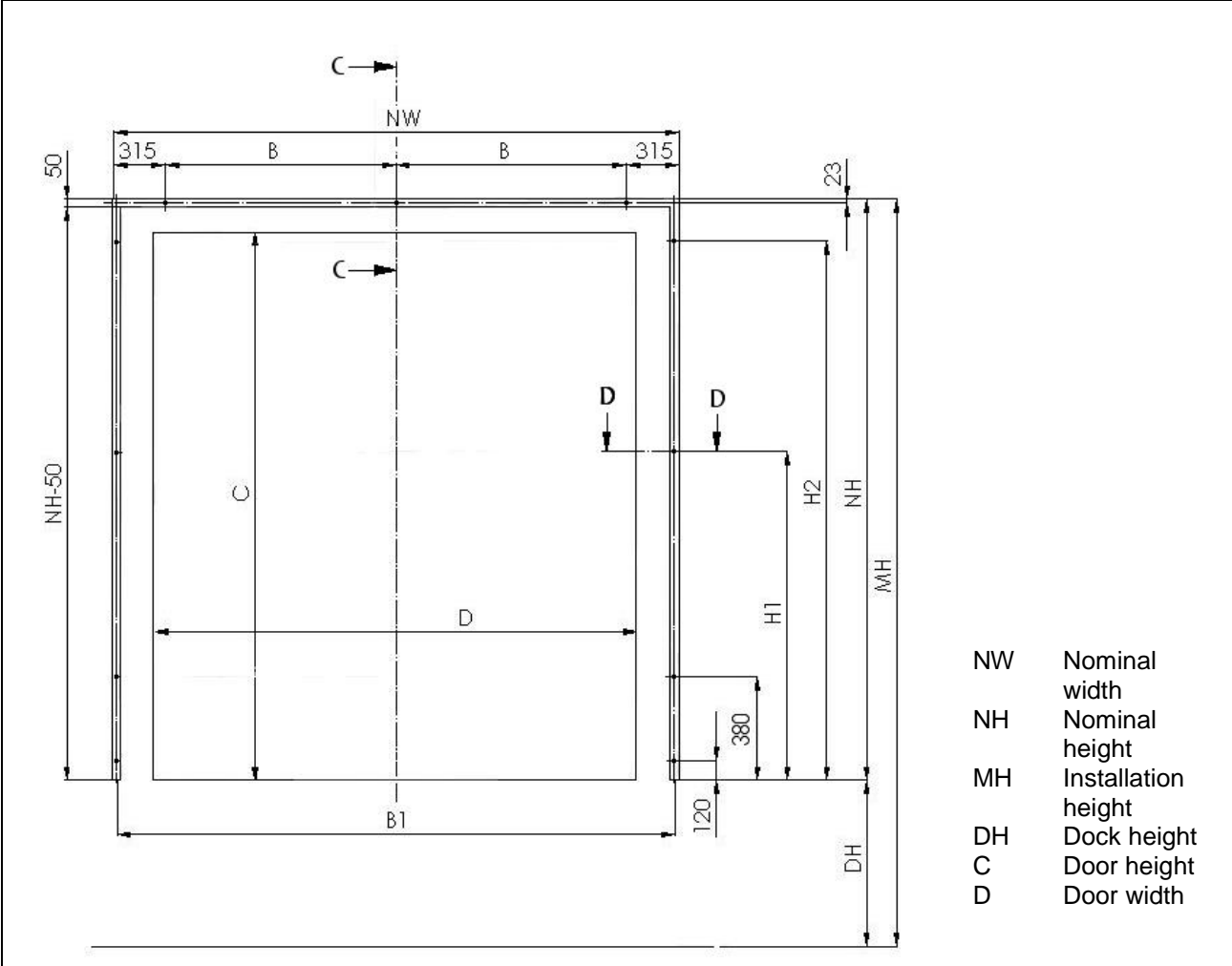

- NW Nominal width
- NH Nominal height
- MH Installation height
- DH Dock height
- C Door height
- D Door width

NW [mm]	B [mm]	B1 [mm]
3200	1285	3154
3250	1310	3204
3300	1335	3254
3350	1360	3304
3400	1385	3354
3450	1410	3404
3500	1435	3454
3550	1460	3504
3600	1485	3554

NH [mm]	H1 [mm]	H2 [mm]
3200	1680	2950
3300	1780	3050
3400	1880	3150
3500	1980	3250
3600	2080	3350
3700	2180	3450
3800	2280	3550
3900	2380	3650
4000	2480	3750
4100	2580	3850
4200	2680	3950
4300	2780	4050
4400	2880	4150
4500	2980	4250
4600	3080	4350
4700	3180	4450

# Wall fixing

- Fixing elements for concrete (heavy duty)

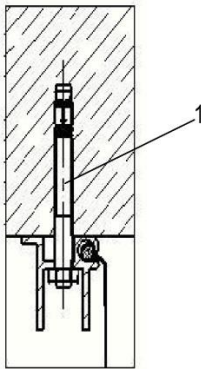

1 heavy-duty bolt W-FA M10x30 (WÜRTH)

- Fixing elements for aerated autoclaved concrete (maximum wall thickness: 300 mm)

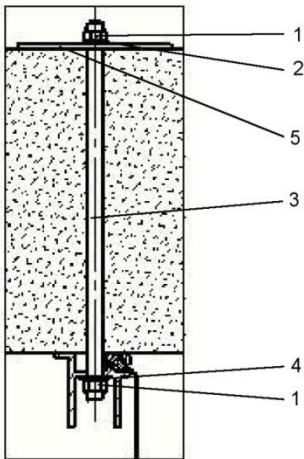

1 hexagonal nut  
2 spring washer  
3 threaded bolt  
4 spacer  
5 shim

- Fixing elements for ISO material (wall thickness 60 mm, 80 mm, 100 mm)

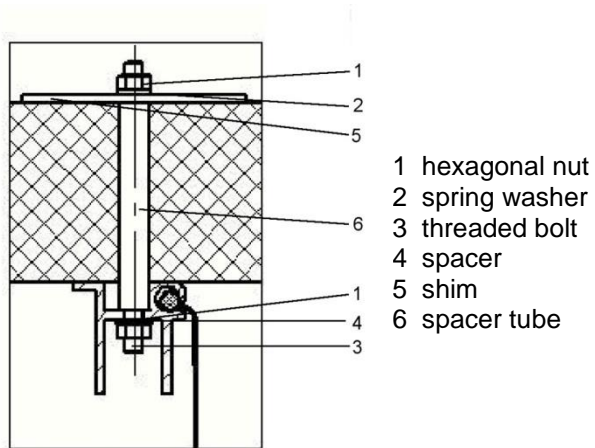

- Fixing elements for plain sheet material (plain sheet thickness 3 mm)

