

load capacity	F1
60 kN	57 kN
80 kN	76 kN
100 kN	95 kN

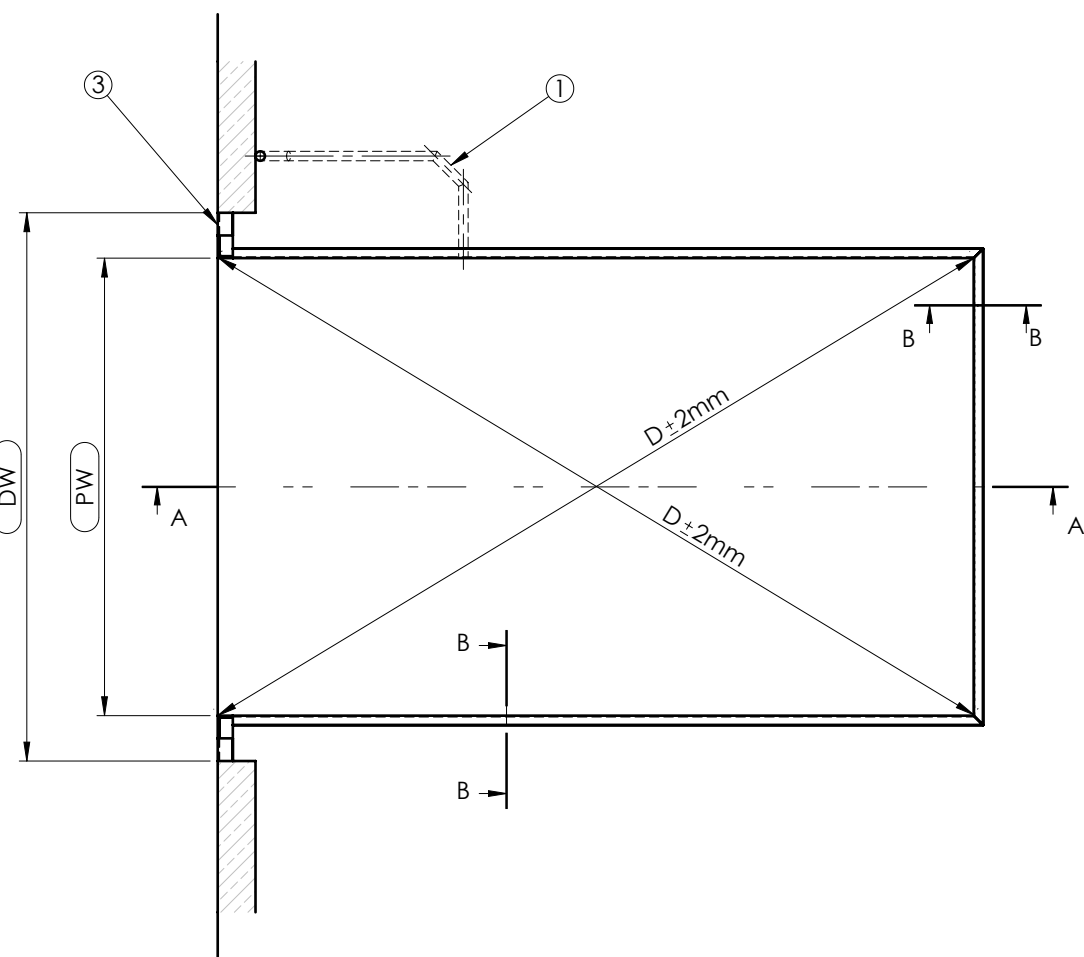

SECTION B-B  
SCALE 1 : 10

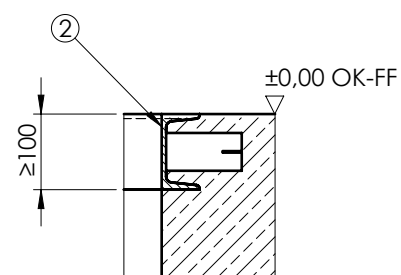

alternative

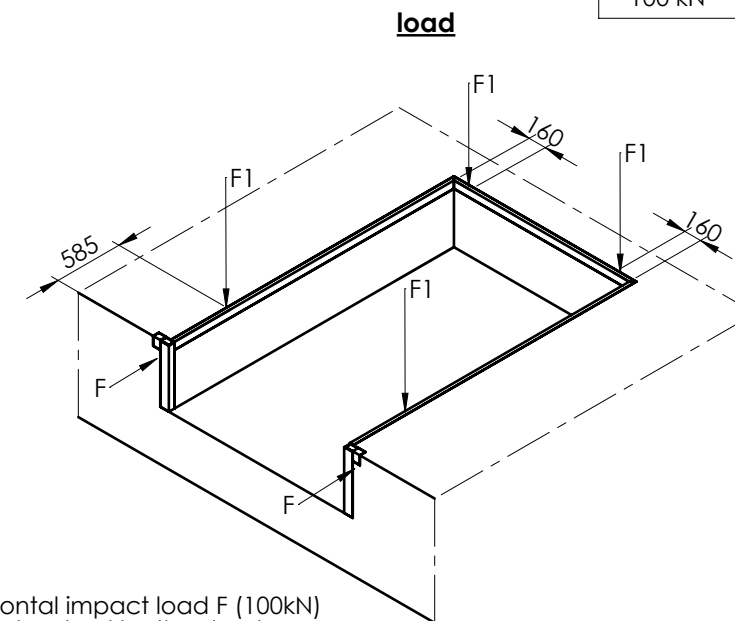
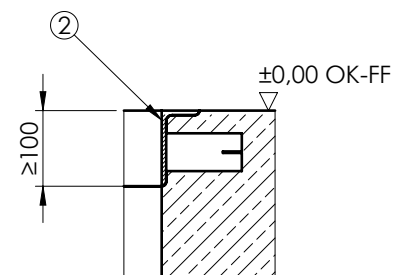

F = The horizontal impact load F (100kN) must be absorbed by the structure.  
F1= cross traffic position

Placement of the conduits: either on the right or on the left side.  
Illustration: installation on the right side

DH	Dock height	by others 1 -Conduit for wiring internal diameter min. 50mm angles <45° 2 -Cast in frame 3 -Steel profile e.g. angle 120x80x10
DW	Door width	
OK-FF	Finish floor level	
OK-H	Yard level	<b>Attention</b> -Do not deviate from the measurements given -The corners of the pit must be square (diagonals must be equal) -The preparation of the pit and the dowels by other
PL	Pit length	
PW	Pit width	
PD	Pit depth	
NL	Nominal length	
NW	Nominal width	
LH	Leveller height	

NL	1750	2000	2000	2250	2500	2500	2750	3000	3000	3500	4000	4500
LH	700	600	700	700	600	700	700	600	700	800	800	800
PL	1735	1985	1985	2235	2485	2485	2735	2985	2985	3485	3985	4485
PD	710	610	710	710	610	710	710	610	710	810	810	810

NW	PW
1750	1770
2000	2020
2100	2120
2200	2220
2250	2270
2400	2420

Installation place drawn: NL=4000  
NW=2400  
LH=800

DIMENSIONS ARE IN MILLIMETERS

DO NOT SCALE DRAWING

REVISION C

MATERIAL:

	NAME	SIGNATURE	DATE
DRAWN	R. Gqciarz		2019-07-15
CHK'D			
APPV'D			
MFG			
Q.A			



TITLE:

PT F  
without tail lift

DWG NO.

PTE.00.00.19-EN

A3

WEIGHT:

SCALE:1:50

EN